



Programmer

FW412

DESCRIPTION

The FW412 Hand-held Programmer is used to set address numbers on detectors and other field devices from Maple Armor. The primary function of the programmer is to allow the system installers to write device address, read device address and read Production Serial Number (PSN).

ATTENTION

Products must be installed per the National Fire Alarm Code, NFPA 72, CAN / ULC-S524, and/or National Electrical Code, depending on the country of the installation. Check the information on equipment used in the system from other manufacturers for instructions and restrictions. The detector should never be installed in the following places: where there is a lot of exhaust gas, kitchens, near fireplaces, boilers, etc. Smoke detectors should not be used with detector guards unless the suit has been evaluated and approved for this case.

NOTE

Do not paint this unit.

Any material extrapolated from this document or Maple Armor's instructions or other materials describing the product for promotional or advertising purposes, or any other purpose, including the description of the application, the use, installation, and testing of the product is the sole responsibility of the user. Maple Armor assumes no responsibility for the use. In no event shall Maple Armor's liability exceed the purchase price of the product.

OPERATION

FW412 Structure:

- a. Base
- b. Test Leads Sockets
- c. LCD
- d. Keypad
- e. External Power
- f. Battery Compartment

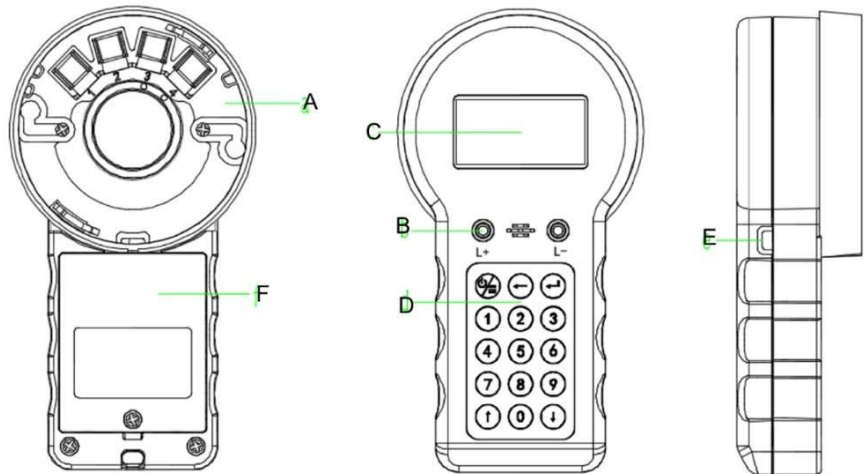

The keypad consists of 15 buttons. In programming mode, the following functions are available:

	Power On; Return
	Execute the operation
	Back Space; Delete
	Up and Down.
Buttons 0 to 9	Write the address; Select the item no. in menu



Mount the detector to its base which is on the back of the programmer (see letter a). Insert the red and black wires in the test lead socket (see letter b) and clamp the clips on the terminals of the devices. Note the polarity when programming the modules

TO POWER ON THE PROGRAMMER



- Put four double A batteries into the battery compartment. Press the button. Or
- Remove batteries and connect the micro-USB adapter to the external power and press the button.

TO WRITE AN ADDRESS NUMBER



- Press the button, the cursor will be located at “1. Write Address” item. Press the button then the programmer will be in WRITE ADDRESS mode.
- Press the intended address number and then the button to confirm. The address should be between 1 and 252. If the input number is outside of this range, the LCD will display “Fail”.

- The programmer will give out a “beep” sound and show “succeed” if the programming succeeds. The programmer will give out two “beep” sound and show “fail” if the programming fails.
- The address can be changed by pressing the  button.
- Pressing the  button, the display will go back to the main menu screen.



TO READ ADDRESS NUMBER

- Press the button “2. Read Address”.
- Press the  button, then the screen will show the address number of the device and will give out a “beep” sound. The programmer will show “000” if the address reading fails.
- Pressing the  button, the display will go back to the main menu screen.

TO READ PSN NUMBER

- Press the button “3. Read PSN”.
- Press the  button, then the screen will show the PSN of the device.
- Pressing the  button, the display will go back to the main menu screen.

PROGRAMMING SET

- Press the button “4. Programmer Set”.
- Press the  button, then the programmer will go into programmer set mode.
- Set the Auto OFF time – Configure the time of automatic power off. Pressing 1 means bypass the Auto OFF feature, pressing 2 means setting the Auto OFF time as 1 minute. Pressing 3 means setting the Auto OFF time as 5 minutes. Pressing 4 means setting the Auto OFF time as 10 minutes. Pressing 5 means setting the Auto OFF time as 20 minutes.
- Set the BL (back light) – Pressing 8 means turning the backlight on (The backlight will automatically turn off when there is no operation for a period of 60 seconds). Pressing 9 means turning off the backlight.
- Pressing the  button, the display will go back to the main menu screen.

TO POWER OFF THE PROGRAMMER

- When the programmer is powered by batteries, the programmer can be shut down by pressing for 2 seconds the  button.

COMPATIBLE DEVICES

Description	Model
Smoke Detector	FW511
Heat Detector	FW521
Manual Stations	FW721/FW721C/FW722/FW722C
Input Module	FW811
Mini Module	FW811M
Dual Input Module	FW812
Input/Output Module	FW821
Relay Module	FW831
Conventional Zone Module	FW841
Addressable Horns/Strobes	FW963A/FW973A/FW983A

SPECIFICATIONS

DC Micro-USB Adapter	5VDC, 1A
Battery	1.5VDC * 4PCS, type "AA"
Operating Current	80mA

CATALOG NUMBER TO ORDER

Model	Description
FW412	Handheld device address programmer with full keypad