

## FW434 & FW435 Module Box

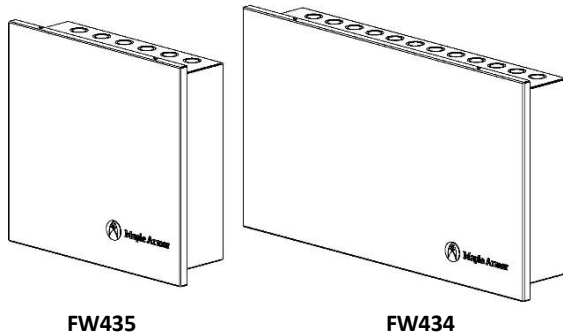

FW435

FW434

### SPECIFICATION

FW434	Weight	21.6lbs (9.8kg)
	Size	622 mm (W) x 114mm (H) x 355.6 mm (D)
	Size	23" (W) x 12" 9/16 (H) x 3" 15/16 (D)
FW435	Weight	11.7lbs (5.3kg)
	Size	381mm (W) x 114 mm (H) x 355.6mm (D)
	Size	13" 9/16 (W) x 12" 9/16 (H) x 3" 15/16 (D)

### DESCRIPTION

The FW434 and FW435 are module boxes allowing the installation of multiple Maple Armor modules into one cabinet. FW434 can fit up to 16 modules and FW435 can fit up to 8 modules. They integrate an external door, two mounting plates, and a backbox. They meet the UL864 10th Edition Listed standard and the ULC-S527 4th Edition Listed standard.

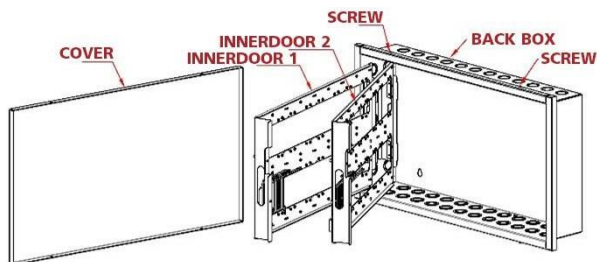

Figure 1 Box Component

### ATTENTION



The products must be installed in accordance with NFPA 72 and/or CAN/ULC-S524, depending on the country of installation. Check the information on equipment used in the system by other manufacturers for any guidelines or restrictions.

### NOTE

Any material extrapolated from this document or Maple Armor's instructions or other documents describing the product for use in promotional or advertising claims, or for any other use, including a description of the product's application, operation, installation, and testing is the sole responsibility of the user. Maple Armor will not assume any liability for such use. In no case will Maple Armor's liability exceed the purchase price paid for a product.

### INSTALLATION

The cabinet must be fastened securely to a clean, dry, shock-free, and vibration-free surface in a protected environment. When mounting the cabinet, position the cabinet clear of obstructions so that the door can open freely.

1. Mount the standard modules and mini-input modules onto each slot on the backbox using four #6-32 screws provided. See Figure 1.

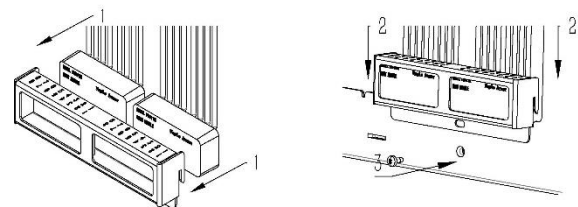
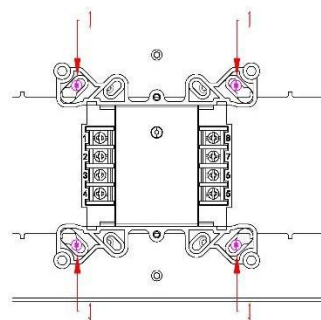

Figure 2 Installation of modules

2. Connect the wire for each module. Refer to respective manuals for more details.
3. Mount the cover onto the backbox using the screws provided.

**INSTALLATION continued**

Figure 3 Cover Mounting

4. Mark the locations of the two upper mounting bolts of the cabinet on the wall. Drill the two holes marked into the wall and screw in the top bolts, leaving a small gap between the wall and each top bolt.
5. Place the cabinet over the two top bolts and allow it to slide down over the bolts.
6. Mark the locations of the two bottom mounting bolts of the cabinet on the wall. drill the two holes marked into the wall and screw in the bottom bolts, leaving a small gap between the wall and each bottom bolt.
7. Tighten all four bolts securely against the back wall of the cabinet.

**MODULE LIST**

<b>Model No.</b>	<b>Specification</b>
FW811	Input Module
FW811H	Input Module
FW811M	Mini Input Module
FW812	Dual Input Module
FW821	Supervised Output Module
FW821H	Supervised Output Module
FW831	Relay Module
FW841	Conventional Zone Module
FW851	Isolator Module
FW859	In-suite Isolator Module
FW951	Sync Module

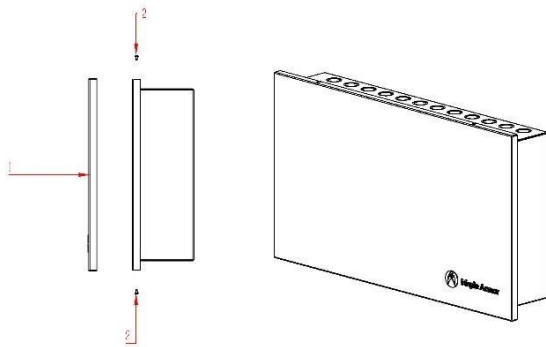
Note: The maximum number of FW951 modules allowed in one box is 4. The maximum alarm load for FW951 is 2 A.