

## FW562-A/B/C, FW562C-A/B/C TWO-WIRE DUCT DETECTOR

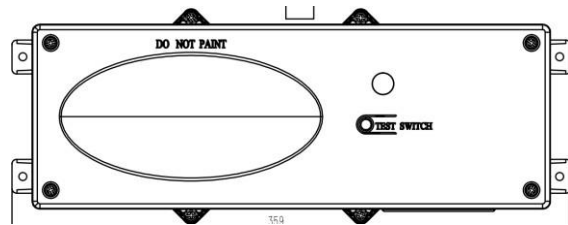

### DESCRIPTION

The FW562-A/B/C and FW562C-A/B/C models are ventilation duct detectors smart designed FOR USE WITH MODEL FW511A DETECTOR HEADS. FW562-A/B/C are UL-listed devices according to UL 268A, and FW562C-A/B/C are ULC listed according to ULC-S529 for fire protection systems. Equipped with a photoelectric smoke detector, the units will signal the presence of a dangerous amount of combustion product in the ventilation system. They are compatible with Maple Armor’s control panel model FW106, FW106C, FW106S, FW106SC.

Note: These detectors are not designed to be used in open areas.

### ATTENTION



The products must be installed in accordance with NFPA 72, CAN/ULC-S524, and/or Canadian Electrical Code depending on the country of installation. Check information of equipment used in the system by other manufacturers for any guidelines or restrictions.

The detector should never be installed in the following locations: areas with excessive exhaust fumes, kitchen areas, near fireplaces, furnace rooms, etc. Smoke detectors are not to be used with detector guards unless the combination has been evaluated and found suitable for that purpose.

### NOTE

Do not paint this device.  
 Any material extrapolated from this document or from Maple Armor’s instructions or other documents describing the product for use in promotional or advertising claims, or for any other use, including a description of the product’s application, operation, installation, and testing is the sole responsibility of the user. Maple Armor will not assume any liability for such use. In no case will Maple Armor’s liability exceed the purchase price paid for a product.

### SPECIFICATION

|                              |  |
|------------------------------|--|
| <b>Nominal Voltage</b>       | 24V dc   |
| <b>SLC Voltage Range</b>     | 17.6 to 28V dc                                     |
| <b>Standby Current</b>       | 0.35 mA  |
| <b>Alarm Current</b>         | 2 mA   |
| <b>Operating Temperature</b> | 32°F to 100°F (0°C to 38°C)                        |
| <b>Operating Humidity</b>    | 0% to 93% RH                                       |
| <b>Dimension</b>             | 329(W) x 114(H) x 51(D) mm<br>(13 1/8 x 4 x 2) in. |
| <b>Weight (with base)</b>    | 4.6 oz (132 g)                                     |
| <b>Mounting location</b>     | Side and top                                       |

### Duct Detector models

a. Applicable to ULC listing required area

| Model           | Air Velocity                                       | Contents  |
|-----------------|--|---|
| <b>FW562C-A</b> | 2000 to 4000 FPM<br>(ft/min)<br>10.2 to 20.3 (m/s) | <ul style="list-style-type: none"> <li>• Duct detector assembly</li> <li>• One exhaust tube</li> <li>• One detector headcover</li> <li>• One <math>\phi 5 * 2</math> hole sampling tube (order separately)</li> </ul> |
| <b>FW562C-B</b> | 700 to 2000 FPM<br>(ft/min)<br>3.6 to 10.2 (m/s)   | <ul style="list-style-type: none"> <li>• Duct detector assembly</li> <li>• One exhaust tube</li> <li>• One detector headcover</li> <li>• One <math>\phi 5 * 4</math> hole sampling tube (order separately)</li> </ul> |
| <b>FW562C-C</b> | 300 to 700 FPM<br>(ft/min)<br>1.5 to 3.6 (m/s)     | <ul style="list-style-type: none"> <li>• Duct detector assembly</li> <li>• One exhaust tube</li> <li>• One <math>\phi 5 * 4</math> hole sampling tube (order separately)</li> </ul>                                   |

b. Applicable to UL listing required area

| Model          | Air Velocity                              | Contents  |
|----------------|---|---|
| <b>FW562-A</b> | 2000 to 4000 ft/min<br>10.2 to 20.3 (m/s) | <ul style="list-style-type: none"> <li>• Duct detector assembly</li> <li>• One exhaust tube</li> <li>• One detector headcover</li> <li>• One <math>\phi 5 * 4</math> hole sampling tube (order separately)</li> </ul>   |
| <b>FW562-B</b> | 1000 to 2000 ft/min<br>5.1 to 10.2 (m/s)  | <ul style="list-style-type: none"> <li>• Duct detector assembly</li> <li>• One exhaust tube</li> <li>• One <math>\phi 5 * 4</math> hole sampling tube (order separately)</li> </ul>                                     |
| <b>FW562-C</b> | 300 to 1000 ft/min<br>1.5 to 5.2 (m/s)    | <ul style="list-style-type: none"> <li>• Duct detector assembly</li> <li>• One exhaust tube</li> <li>• One detector head baffle</li> <li>• One <math>\phi 5 * 2</math> hole sampling tube (order separately)</li> </ul> |

### Sampling tubes selection

Note: To fit different duct widths, 12, 18, 24, 36, 42 inches length sampling tubes are optional. If you need a longer length, you can combine shorter ones with the tube connector.

| Model       | Description                       |
|-------------|-----------------------------------|
| FW561-ST-12 | 12 inch's Air Sampling Inlet Tube |
| FW561-ST-18 | 18 inch's Air Sampling Inlet Tube |
| FW561-ST-24 | 24 inch's Air Sampling Inlet Tube |
| FW561-ST-36 | 36 inch's Air Sampling Inlet Tube |
| FW561-ST-42 | 42 inch's Air Sampling Inlet Tube |

### Pre-Installation

**IMPORTANT: Technicians will have to be certified by Maple Armor on the installation of the Maple Armor duct detector before they can verify & certify them.**

#### Step 1

We recommend that the duct detector assembly be installed 6 duct widths from any bends or inlets. This is to maximize the sensor efficacy. There will be less air turbulence and if smoke is present, the air and smoke will be better mixed. See Figure 1

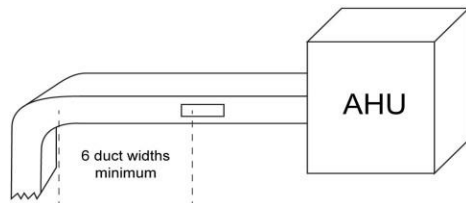

Figure 1

#### Step 2

The duct detector assembly must be installed on the supply side of the air handling unit.

#### Step 3

Located assembly upstream of air humidifiers and cooling coils.

#### Step 4

A duct detector can be mounted on a round duct detector, as long as the diameter is 12 inches or more.

#### Step 5

If possible try to install the duct detector in an accessible location.

#### Step 6

If the duct detector is hidden in a ceiling, you will need to install a remote indicating light in the ceiling under the detector to show the location.

#### Step 7

It can be installed horizontally on a duct as narrow as 6 inches and vertically on a duct as wide as 16 inches.

#### Step 8

For more help on model FW562C you can consult CAN/ULC-S524-06 section 5.8 & Figure 24 & 25; for model FW562 you can consult NFPA 90A.

#### To install the duct detector:

1. Tape the template to the duct housing and drill (or punch) the mounting holes at the desired mounting location as indicated in Figure 2.

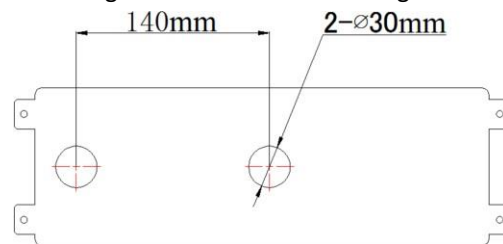

Figure 2 Mounting Hole Illustration

2. Slide the sampling tube into the duct detector housing assembly. Note: The sampling tube must be installed with the air inlet holes facing the airflow, check duct housing surface for any indication of airflow, or ask the HVAC installer.
3. Mount the duct smoke detector on the HVAC duct and secure it using four sheet metal screws provided.

If using 2 lengths of air sampling tube, drill a 1/2-inch hole on the opposite side of the duct for the tube to pass through and cut the tube so that approximately one inch of the tube extends through the duct. Plug the third and fourth holes using the rubber stopper provided, for models FW562C-A and FW562-C.

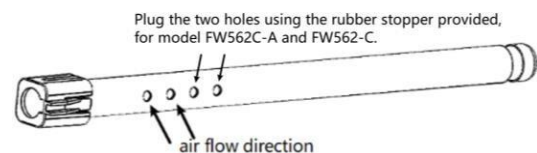
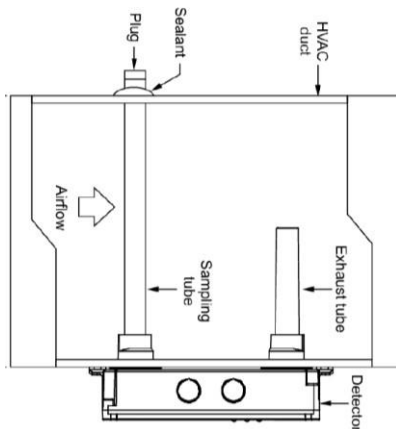

Figure 3 sampling tube installation

The sampling tubes should be supported at both ends of the duct as shown in figure 4.



**Figure 4 Duct Detector Installation**

4. Remove any rough edges from the holes.
5. Seal the opening around the tube with an approved duct sealant.
6. Verify that all field wiring is free of opens, shorts, and ground faults.
7. Make all wiring connections as shown in Figure 5.

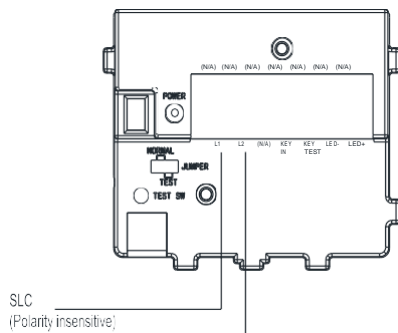

**Figure 5 Wiring Diagram**

8. Set the internal smoke detector address via the handheld programmer FW412 or via panel FW106. Refer to individual manuals for details. Note: The duct FW562-A/B/C/ or FW562C-A/B/C share the same address with the smoke detector model FW511.
9. You must perform an air differential pressure test by using an Air Velocity Meter ex: Dwyer model 460 or Reed R3001 or equivalent. Write down the air pressure differential value, next you must select the appropriate model that falls in the specified operating range.

10. Duct detector assembly contains all 3 models in a kit, the technician must set up the duct detector per 1 of 3 figures. See below for proper operation and certification.
11. The FW562-A/B/C can be configured in 3 ways. For model, FW562-A see figure 6, for model FW562-B see figure 7 and for model FW562-C see figure 8; the FW562C-A/B/C can be configured 3 ways also, for model FW562C-A see figure 9, for model FW562C-B see figure 10 and for the model, FW562C-C see figure 11.

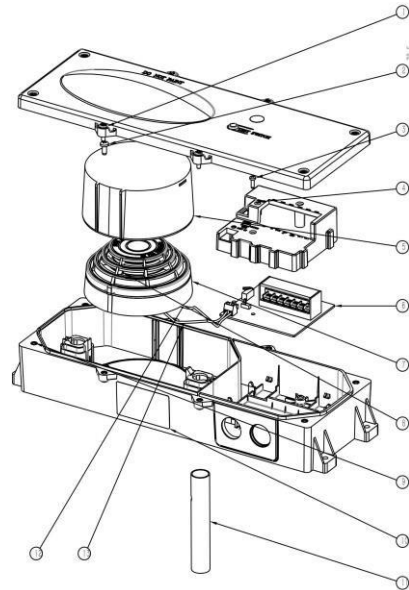

**Figure 6**

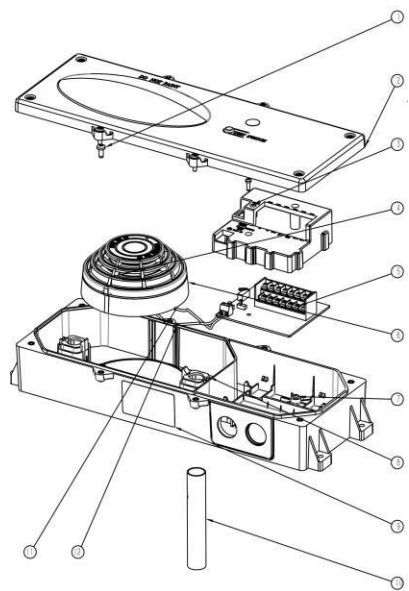

**Figure 7**

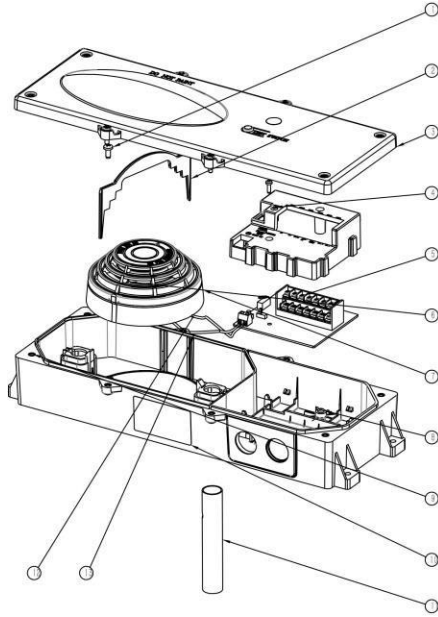

Figure 8

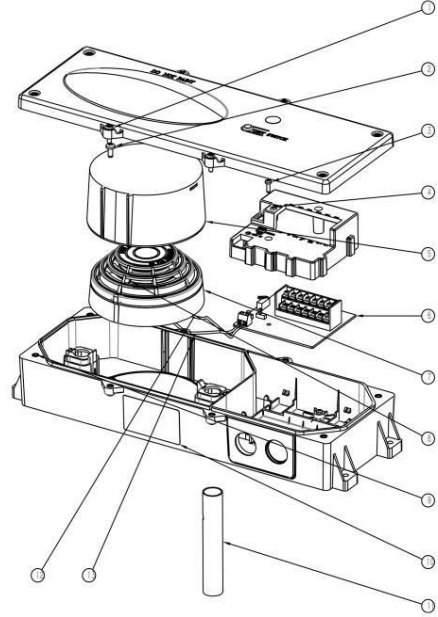

Figure 10

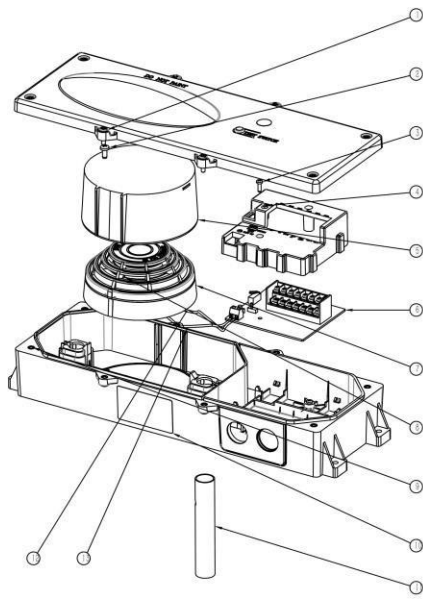

Figure 9

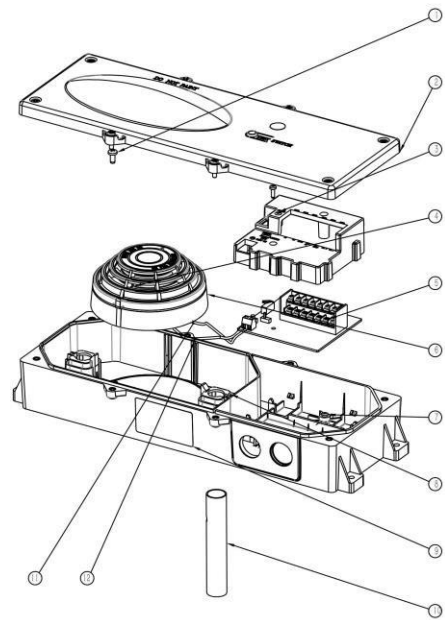

Figure 11

When the part number is determined, use the blank sticker to cover the additional part numbers shown on the label. See Figure 12.

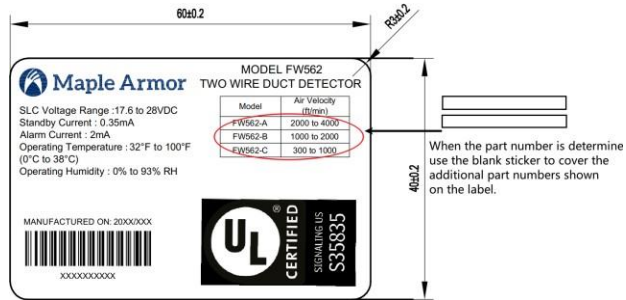

Figure 12 Label check

12. To verify the air pressure differential  
 To verify air pressure differential, air must be moving through the HVAC system.

Connect a suitable air pressure differential meter model Reed R3001 or equivalent to the sampling tube and exhaust tube openings as shown in Figure 13.

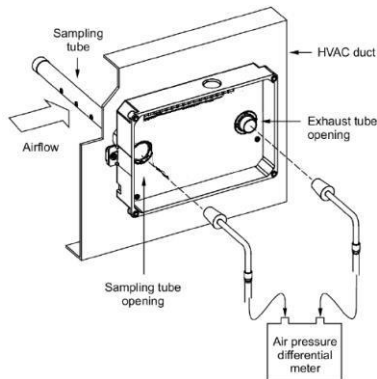

Figure 13 Air Pressure measure

13. Verify that the air pressure differential measured falls within the specified operating range of the detector.

| Model    | Air pressure   |
|----------|--|
| FW562C-A | 0.36 to 1.53 iwg (inches of water)<br>90 to 380 Pa (Pascals) |
| FW562C-B | 0.04 to 0.4 iwg (inches of water)<br>9 to 100 Pa (Pascals)   |
| FW562C-C | 0.004 to 0.06 iwg (inches of water)<br>1 to 15 Pa (Pascals)  |
| FW562-A  | 0.32 to 1.41 iwg (inches of water)<br>80 to 350 Pa (Pascals) |
| FW562-B  | 0.1 to 0.4 iwg (inches of water)<br>25 to 100 Pa (Pascals)   |
| FW562-C  | 0.004 to 0.14 iwg (inches of water)<br>1 to 35 Pa (Pascals)  |

14. If the air pressure differential measured does not fall within the specified operating range of the detector, make sure the sampling tube air holes are not obstructed and are facing the HVAC system airflow.

15. After completing the installation of the duct smoke detector, test the detector to ensure it is operating correctly.

**Main function**

Models FW562-A/B/C and FW562C-A/B/C Duct Smoke Detectors utilize photoelectric smoke detectors for the detection of smoke. When sufficient smoke is sensed, an alarm signal is initiated.

**Test function**

- Alarm simulation: Pressing the TEST SW can simulate an alarm condition.
- Cover tightness monitor: When the JUMPER switch is on the NORMAL side, a trouble event will be annunciated when the cover is not secured properly. When the JUMPER switch is on the TEST side, this feature will be bypassed. Note the TEST mode should only be used in installation and field testing.

**To clean the duct smoke detector**

1. Disable the detector/zone to prevent false alarms.
2. Remove the detector's cover then power down the detector by disconnecting the SLC wiring.
3. Using a vacuum cleaner, or clean compressed air, with a soft bristle brush, remove loose dirt and debris from inside the detector housing and cover.
4. Remove dirt and other contaminants from the gasket on the detector's cover using isopropyl alcohol and a lint-free cloth.
5. Squeeze the retainer clips on both sides of the optic housing then lift the housing away from the printed circuit board.
6. Gently remove dirt and debris from around the optic plate and inside the optic housing.
7. Replace the optic housing and detector cover, and then connect the SLC wiring.

Return the product for reparation if it fails to flash or alarm during testing. Do not disassemble the product without permission.